



lets **GO GREEN**  
to get our globe  
**CLEAN**

# CUBICLE PARTITION SYSTEM

---

FOR OFFICES & TOILETS

-  Ahmedabad, Gujarat INDIA
-  +91 99747 00352, +91 98985 00475
-  info@eplast.in
-  www.eplast.in



Go to Website

## COMPANY PROFILE



E Plast Industries LLP was founded in the year 2011 by Mr. Mohan Varsani and the company is now a key player in the fabrication industry, supplying a wide range of PVC products, PVC profiles.

At present the company has pan India presence with unit located at Ahmedabad which manufactures Prefab House (Insulated Sandwich PUF Panel), Bunk House, Portable Cabin, Security Cabin, School Rooms, Insulated PUF Roofing Panel, Prefab House, PVC Doors, uPVC Door & Window Systems.

Our strategy is to create world class products, so that we can satiate the demands of our consumers and thus, surpass our contemporaries in competition. It is with our integrated efforts and customer service that we have managed to keep

our growth rate on an upward swing; in spite of the present economic turmoil, which has adversely affected people's lives and ways in which business is being conducted.

E Plast Industries LLP is passionate about the role of prefabrication in transforming our built environment, such as decreasing construction time frames and construction waste while increasing quality, productivity and affordability.

At E Plast Industries LLP, we look forward to customer satisfaction. Our main objective is to ameliorate our customers and stakeholders, and in the process strengthen the roots of our organization, so that we can emerge as a behemoth in the fabrication industry.



### OUR MISSION

Our mission is to create cleaner safer world by using environment friendly products



### OUR VALUES

we believe in the core values of people, operational excellence, innovation and integrity. These values are like assets that consolidate us in our march towards a greater future.



### OUR VISION

To create a world class fabrication manufacturing industry that pursues Quality, Cost Reduction and productivity improvement technics leading to customers satisfaction and carry out environment friendly products which will help make our earth a cleaner, safer place for generations to come.

## OUR CERTIFICATION

WE ARE  
 ISO 9001:2015, 14001:2015, 45001:2018, 50001:2018,  
 GREENGUARD COMPLIANCE, BIFMA LEVEL 1 2 & 3  
 CERTIFIED COMPANY  
 WE WORKS IN A SYSTEMATIC WAY



## WHY? WE

- High Quality Products
- State of the art Technology
- Timely Delivery & Commitment
- Manufacturing Facility
- Value for money
- Practical & Cost Effective service to clients
- Talented professional services department
- Customer Support







## PRODUCT OVERVIEW

Give an elegant makeover to your restrooms and offices with an exclusive range of Cubicle Partition System from E-Plast Build Techno Industries LLP. We are the leading manufacturers of Cubicle Partition Toilet and Office Partition in Gujarat, we offer types of divider panels Foamsheet and WPC Sheets, doors and connecting panels in Nylon or SS Material, for unique appeal of restrooms and office working space we offer colors and designs as per client's requirement.

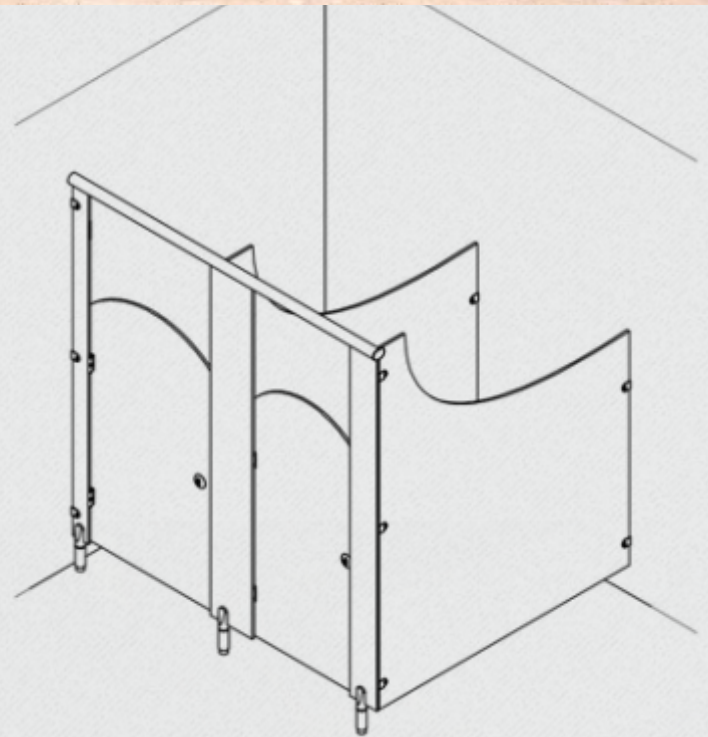

## FLAWLESS QUALITY

We are AN ISO 9001:2015, 14001:2015, 18001:2017 certified company hence we never compromise with quality. The Cubicle Partition System are available in various sizes, shapes and colour hues. They are built with solid pvc foamsheet or wooden pvc sheets, with nylon and stainless steel hardware fitting.

## KEY FEATURES OF CUBICLE PARTITION SYSTEM



Water Resistant



Impact Resistant



Range of Colors



Stability



Design Flexibility



## MADE FOR

- Commercial Buildings
- Educational Premises
- Transportation Hubs
- Shopping Malls
- Public Places
- Offices
- Gyms
- Pools
- Theatres
- Factories etc.



## ADVANTAGES

- A profound spacious appeal with an extremely amazing combination of science & beauty.
- Available in various sizes, shapes and colour hues
- Easy on your senses & a charm to use.
- Designed for providing better durability and performance
- Hyper-advance Designs
- No wet work involved. Helps reduce load and also saves on space compared to brick wall partitions.
- Fast pace of installation.
- Top & bottom gaps not only ensure air ventilation but also aid zero water & dust logging
- Hygienic and easy to maintain
- Safe & easy to handle by children & the handicapped.







**NYLON SYSTEM  
HARDWARE  
FITTINGS**



**LOCKER SYSTEM  
SS HARDWARE  
FITTINGS**





## CUBICLE PARTITION OFFICE



## CUSTOMIZED DIGITAL PRINTED TOILETS





# SOME OF OUR CLIENTS

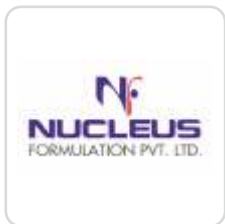



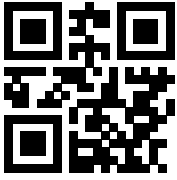

GO TO WEBSITE



ADD CONTACT



## E-Plast Industries LLP

F/12, Vikram Plaza, Nr. Gota Railway Crossing (Bridge), Opp. Vishwakarma Temple, Gota-Chandlodiya Road, Ahmedabad - 382481, GUJARAT, INDIA.

Mob.: +91 99747 00352 | +91 98985 00475

Email: [info@eplast.in](mailto:info@eplast.in)

URL: [www.eplast.in](http://www.eplast.in)

Zector inc. 9998848775

WE BELONGS TO KAKA GROUP OF COMPANY

